

S6104P

03-04 DODGE 2500/3500 5.9L CUMMINS, TURBO BACK, 4" SINGLE SIDE

MBRP
INC.
PERFORMANCE EXHAUST
March 23, 2017

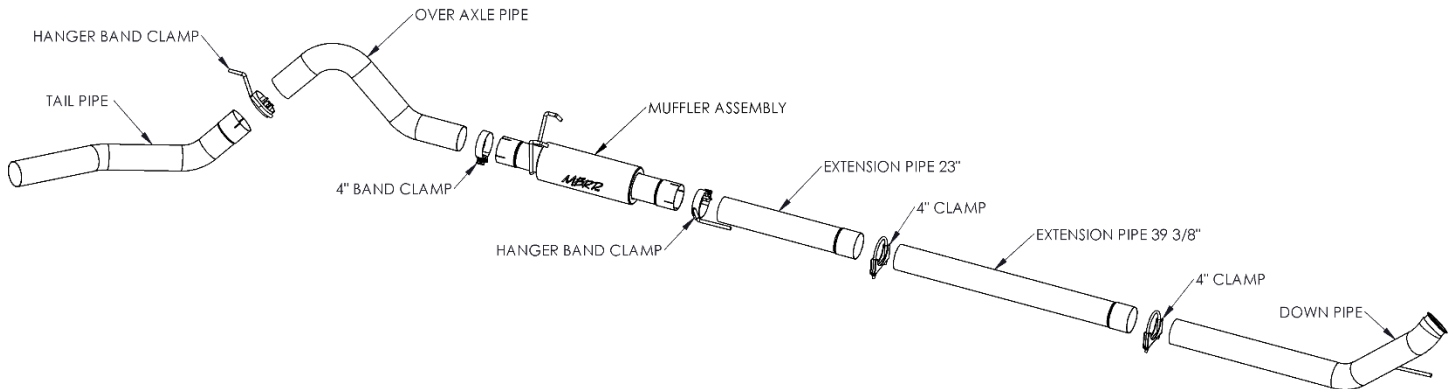

PLEASE READ BEFORE STARTING INSTALLATION

MBRP Inc. has made every effort to ensure that all components of this system are of superior quality and properly packaged. It is the installer's responsibility to ensure that all components are present and fit together as shown. Please also ensure that all components are undamaged before removal of the factory exhaust. Finally check that this system properly matches the make and model of the vehicle and will not interfere with previous or planned modifications.

Removal of stock system:

1. Apply a penetrating lubricant liberally to all exhaust fasteners, hangers and rubber insulators.
2. Remove the exhaust system from the rubber insulators and remove all of the clamps from the system.
3. Separate the slip joint behind the muffler and remove the tail pipe. Next, separate the slip joint connecting the down pipe and the extension pipe to remove the muffler and extension pipe. Finally loosen the band clamp connecting the down pipe to the turbo and remove the down pipe. **Do not discard the band clamp as it is required for the installation.**

Installation of MBRP Inc. Performance Exhaust:

1. Install the Down Pipe in the same position as the stock down pipe by sliding the hanger into the OEM hanger bracket and then attaching the flared end to the turbo using the stock band clamp. Do not fully tighten until all components are in place.
2. Install the Extension Pipe 39 3/8" over the Down Pipe. The Extension Pipe 23" is also required for the Quad Cab Long Bed. The Extension Pipe 39 3/8" may require cutting to accommodate vehicles other than the Quad Cab long bed. (Installation tip: Temporarily hang the muffler and Mid Pipe in place using the three OEM rubber hangers and measure from the muffler to the down pipe to determine the length required.)
3. Install the Muffler, Hanger Band Clamp over the Extension Pipe and into the OEM rubber hangers.
4. Install the Tail Pipe and Hanger Band Clamp onto the Over Axle Pipe. From the rear of the truck, slide the assembly over the axle and attach to the outlet of the Muffler. Install the Hanger Band Clamp to the factory rubber insulator.
5. Install the remaining Clamps around the pipes where required. Adjust the Tail Pipe and check along the whole length of the exhaust system to ensure there is adequate clearance around the fuel and brake lines or any wiring. If any interference is detected relocate or adjust.
6. Start at the front of the exhaust system and begin tightening all connections. Recheck for Interference after tightening and adjust if required.

Congratulations! You are ready to begin experiencing the improved performance and driving excitement of your MBRP Inc. performance exhaust system. We know you will enjoy your purchase.